

# The Lockerby Newsletter

LCS News Update | May 4 - 8, 2020

## VIKINGS SHARING THEIR GRATITUDE!



This week, our Student Council asked our Viking community to share their pictures of gratitude. Above are just some of the submissions that were received! Great job Vikings! Keep staying positive and continue to do your best during these challenging times!

Keep reading this week's Newsletter for further information regarding updates about Rainbow District School Board and Lockerby Composite's Distance Learning Plan (starting on Page 9).

## WHAT'S HAPPENING IN OUR ONLINE CLASSES?

### Science

This week, students in Grade 9 STEP Science built their own electroscopes to demonstrate static electricity at work. Gillian built an electroscope out of a glass, a paper clip, a plastic lid, and some foil. She charged her plastic paint brush with the carpet and then used it to show how charges can move to the foil leaves in the glass. The foil leaves separated because they had carried the same charge!

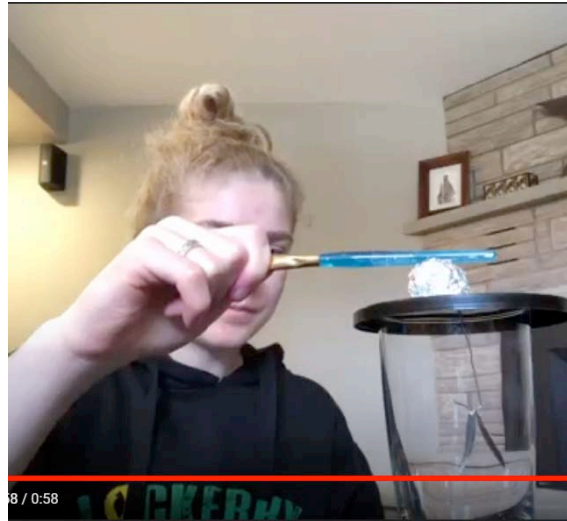
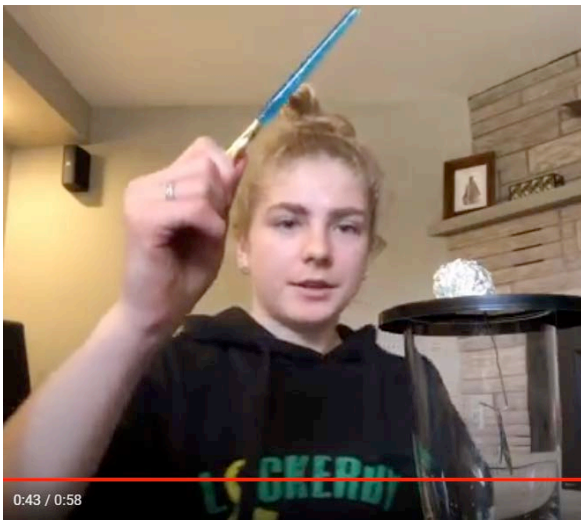

Our Grade 9 STEP Vikings also used an online program called 'Jamboard' to take pictures of circuits and convert them to circuit diagrams.

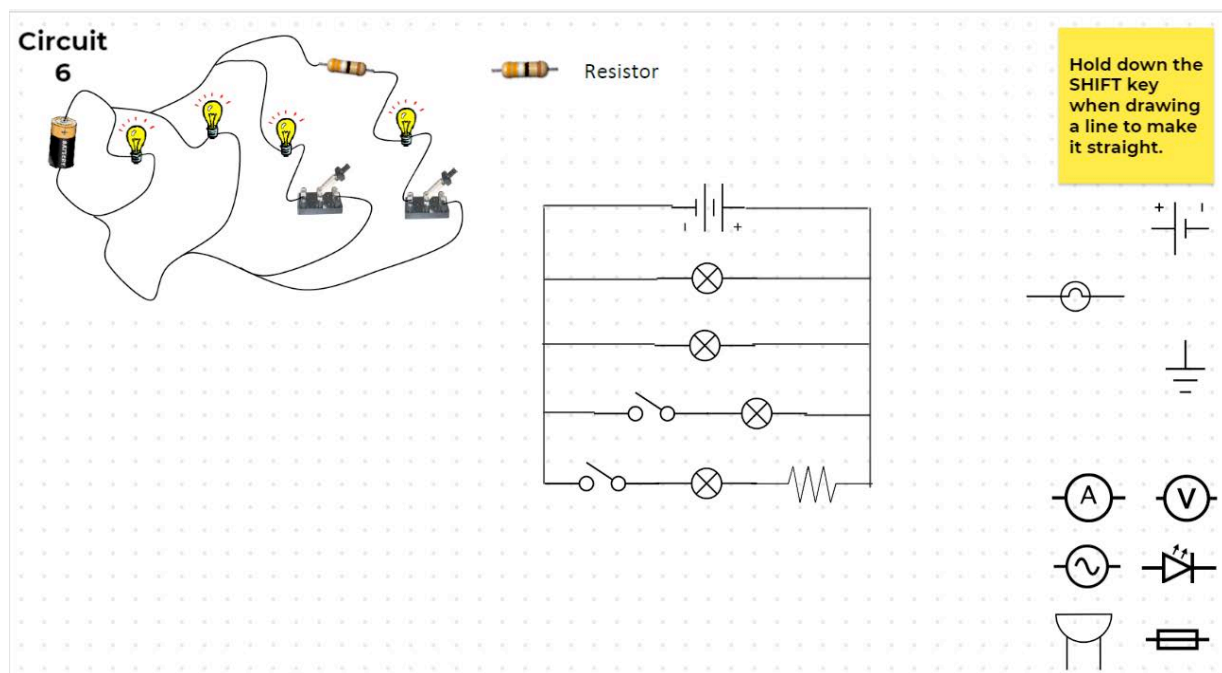

## WHAT'S HAPPENING IN OUR ONLINE CLASSES?

### Geography

Our students in Grade 9 Geography used TikTok and other video recording technologies this week to warn others against the negative effects of an increasingly problematic occurrence: overtourism. Ever the problem-solvers, they also provided useful tips that promote sustainable tourism for the future!



# LOCKERBY

THE SCHOOL OF SCIENCE AND TECHNOLOGY

## WHAT'S HAPPENING IN OUR ONLINE CLASSES?

### Français

Students in Grade 9 Core French were working in real-time during our synchronous lesson this week and did an excellent job conjugating verbs to the passé composé. Bravo les élèves!

Revenir (to come back) PP: revenu K.M.	Monter (go up) PP: monté J.P.	Rentrer (to go back in) PP: rentré A.M.	Sortir (to leave) PP: sorti A.Z.	Venir (to come) PP: venu J.C.
Je suis revenu	Je suis monté	Je suis rentré	Je suis sorti	Je suis venu(e)
Tu es revenu	Tu es monté	Tu es rentré	Tu es sorti	Tu es venu(e)
Il est revenu	Il est monté	Il est rentré	Il est sorti	Il est venu
Broyden est revenu	Broyden est monté	Broyden est rentré	Broyden est sorti	Broyden est venu
Elle est revenu	Elle est monté	Elle est rentré	Elle est sortie	Elle est venue
Kyara est revenu	Kyara est monté	Kyara est rentré	Kyara est sortie	Kyara est venue
Nous sommes revenu	Nous sommes monté	Nous sommes rentré	Nous sommes sorti	Nous sommes venu(e)s
Vous êtes revenu	Vous êtes monté	Vous êtes rentré	Vous êtes sorti	Vous êtes venu(e)s
Ils sont revenu	Ils sont monté	Ils sont rentré	Ils sont sorti	Ils sont venu
Jon, Josh, et Aj	Jon, Josh, et Aj sont monté	Jon, Josh, et Aj sont rentré	Jon, Josh, et Aj sont sorti	Jon, Josh, et Aj sont venu
Elles sont revenues Cassidy et Sahba	Elles sont monté	Elles sont rentré	Elles sont sortie	Elles sont venues

### Chemistry

Students in Grade 12 STEP chemistry used a program called 'Molview' this week to make, visualize, and manipulate 3D structures of organic compounds to gain a better understanding of isomers and the properties of these molecules! It may have been a challenge, but our Vikings rose to the occasion!

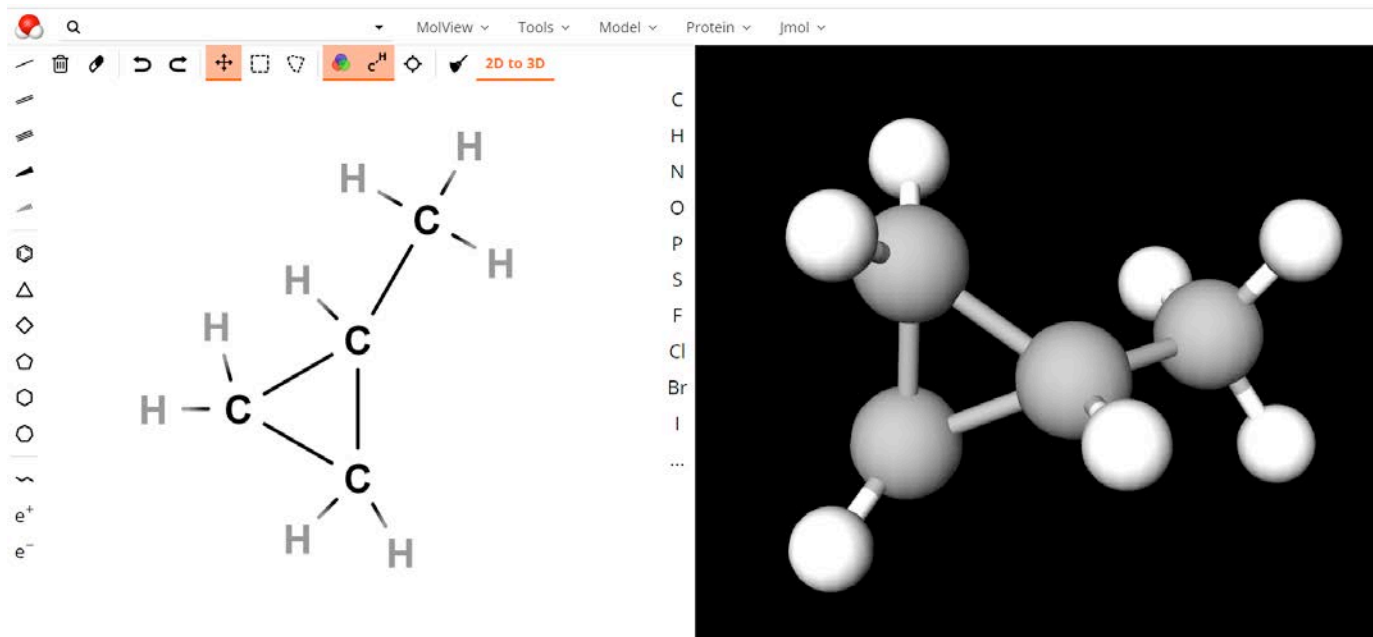

## WHAT'S HAPPENING IN OUR ONLINE CLASSES?

### Visual Arts

Unusual times call for unusual measures! This week, our artists were challenged to make art on an unusual surface or use non-traditional materials to produce an artwork. With students at home, art supplies are varied, and sometimes scarce. A challenge for some, but not for Lockerby's Vikings. At school, we wouldn't ordinarily paint on wood because we have canvases but, if wood was good enough for artists before the Renaissance (and beyond), then it's good enough for us. And we didn't stop there! How about drawings on books or a Shopper's Drug Mart flyer? No problem for this crew. Painting a lime or the back of a mirror? Absolutely! Anything goes. Check out just a few of these incredible creations. We are so proud of you all for your commitment and your creativity! Keep up the great work!

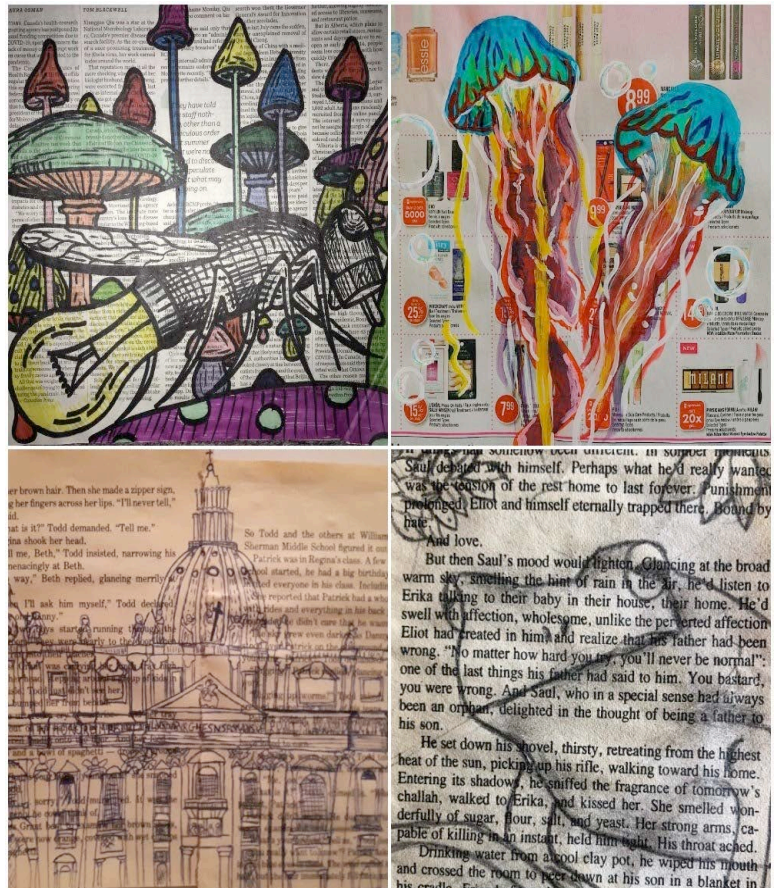

### Technological Studies

Our students continue to be hard at work this week, and that certainly includes our Robotics students. Our Robotics Team would like to send out a thank you to the Sudbury Branch of the Canadian Institute of Mining (CIM), who has been collectively spreading money around the community for years. This year they spread around about \$10,000 to support several local initiatives. Lockerby students have once again benefited from their generosity receiving funds to purchase more VEX robotics equipment to support our Robotics Program. These funds will continue to allow students to practice their problem solving skills as part of a team!

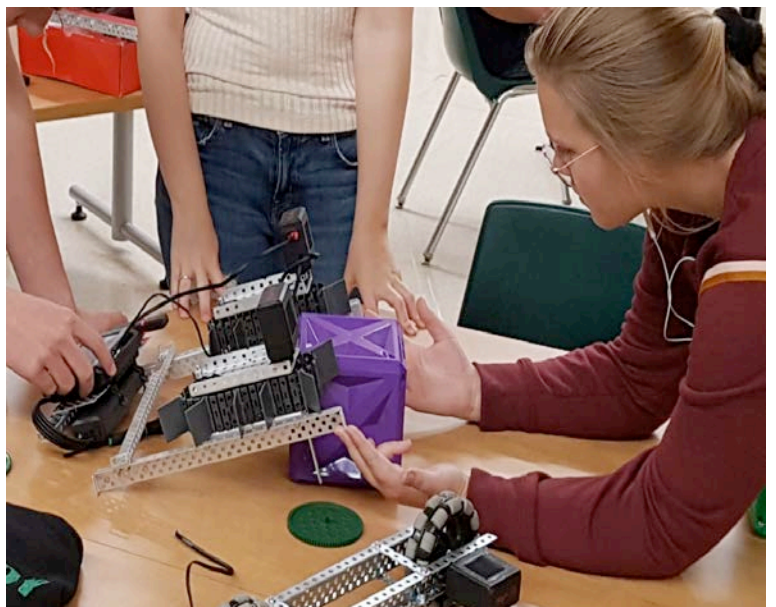

## THIS WEEK IN VIKINGS ATHLETICS . . .

### Message from the Lockerby Athletics Association (LAA)

We're officially kicking off our first week of seasonal sports recaps and MVPs and we are starting with a fall favourite: Flag Football. This year, our team took home 3 wins, defeating College Note-Dame, Lo-Ellen Park, and St Benedict's. The team made some great bonds and memories this year, and we can't wait to see what the 2020 - 2021 season brings!



**2019/2020  
Flag Football  
Offensive MVP**

**Bio**  
**Name:** Krista Korzeniecki  
**Grade:** 11  
**Seasons played:** 3  
**Position:** Wide Receiver  
**Favourite Play:** Fly  
**Most Excited For Next Season:** Our op team



**2019/2020  
Flag Football  
Offensive MVP**

**Bio**  
**Name:** Kennedy Ward  
**Grade:** 12  
**Seasons played:** 3  
**Position:** Quarter Back  
**Favourite Play:** Fly's or the X  
**Best Memory :** Stacie's first touchdown



**2019/2020  
Flag Football  
Defensive MVP**

**Bio**  
**Name:** Halle Bertrim  
**Grade:** 10  
**Seasons played:** 2  
**Position:** Long safety  
**Favourite Play:** Interceptions  
**Most Excited For Next Season:** Getting pumped before games

# KUDOS!



## TEACHER APPRECIATION DAY: MAY 5<sup>TH</sup>, 2020

### Message from Lockerby's Student Council

Greetings Teachers:

As you may know, May 5<sup>th</sup>, 2020 is Teacher Appreciation Day during our Education Week.

In honour of this day, we would like to thank you for all of the efforts that you have been putting towards our education. We truly recognize the countless hours that you have put towards live video calls, creating assignments, and challenging us intellectually. This effort has allowed us students to thrive in a situation as tough as the one we are currently in. The support you have shown each and every one of the students has been extremely beneficial as everyone is going through a time of isolation and struggle. Having the opportunity to communicate with other classmates and socialize online brings us a sense of comfort within our homes. Everyone is currently trying to familiarize themselves with this new change and we wouldn't be able to adapt and transition as well as we have without your efforts and guidance. Your dedication to maintaining structure in our education system is of the utmost importance to students. It keeps consistency in our curriculum and prepares us for years to come. As we continue to advance in our programs throughout this pandemic, we acknowledge the efforts that our Lockerby staff is making in order to make this situation more comfortable, and functional for students. The Lockerby student body as well as other staff members are very appreciative of everything you do for all of us with and without distance learning. We are extremely grateful to have such an amazing group of individuals creating a Viking community we can all consider a second family. Thank you for all that you do!

Composed by Summer L., Rayaq S. & Jasmine J.

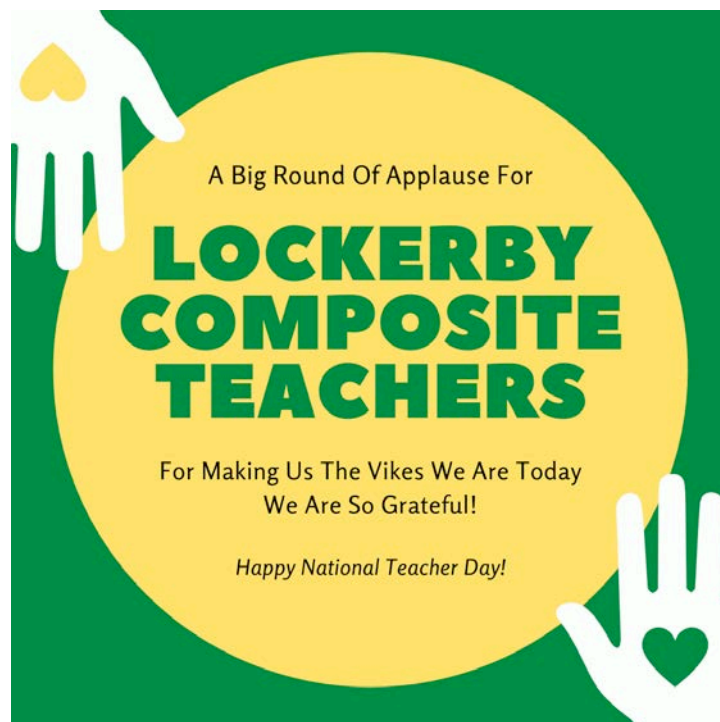

## STUDENT SERVICES

### Scholarships

Ontario Public School Boards' Association - Friday, May 29<sup>th</sup>, 2020

On behalf of the Ontario Public School Boards' Association (OPSBA) Northern Regional Chair Mark Mannisto, OPSBA is pleased to announce the creation of a new scholarship for graduating secondary students, The Public Property Assessment Network Scholarship. This scholarship will be awarded in the amount of \$1,000 to one recipient in the OPSBA Northern Region.

For additional details please see Lockerby's Scholarship Webpage:

<https://lockerby.rainbowschools.ca/student-services/financial-aid/current-scholarships/>

### Enrichment

Laurentian University - Passport to Post Secondary

The proposed event will be a presentation aimed at parents of Grade 11 students, to assist them in the transition process of their student/young adult to Grade 12. This will cover an overview of ensuring course selection does not limit students' goals, questions to ask through the upcoming post-secondary process, and an overview of the year ahead: May to June of Grade 11 all the way to the September of their first year in University in 2021.

Laurentian University will be offering the presentation digitally over the easily accessible platform, Zoom. The presentation will be about 45 minutes followed by questions. The presentation dates are as follows:

French:	Tuesday, May 19 <sup>th</sup> , 2020 at 1:00pm
French:	Tuesday, May 19 <sup>th</sup> , 2020 at 5:00pm
English:	Thursday, May 21 <sup>st</sup> , 2020 at 1:00pm
English:	Thursday, May 21 <sup>st</sup> , 2020 at 5:00pm

## AP EXAMINATIONS: GOOD LUCK!

The Viking Community would like to wish all of our AP students good luck on their upcoming final examinations. We are very proud of your accomplishments and we wish you all continued success. Over the next two weeks, we will have 40 students writing 53 examinations including: AP Biology, AP Calculus, AP Computer Science, AP English and Language Composition, AP Environmental Science, and AP French Language, as well as submitting projects in both of our AP Capstone Program courses, Seminar and Research!





## LCS DISTANCE LEARNING MESSAGES/UPDATES (AS OF MAY 7<sup>TH</sup>, 2020)

- Grade 11 and 12 students will be receiving a copy of their 'Mark Summary Report' (for all of their classes) dated May 8<sup>th</sup>, 2020 in the mail over the next several days.
- Grade 9 and 10 students will be receiving a copy of their 'Mark Summary Report' (for all of their classes) in the mail over the next week or two.
- AP students will be beginning their online examinations the week of May 11<sup>th</sup>, 2020. Good luck!
- If students, parents/guardians have questions about mental health and well-being, please contact a member of the Rainbow District School mental health team by calling 705-665-3339 or 705-669-7732 between 10:00am and 3:00pm, Monday to Friday.
- A reminder that morning announcements will be posted in homeroom Google Classrooms each school day. These announcements contain important day-to-day information for students. Our morning announcements are also posted on our website under 'Frequent Links.'
- We continue to take daily attendance. A reminder to all students to please sign-in to all of their classes each day.



**Learning together  
while safely apart**

**To families:**

**Thank you for embarking on this journey  
with an open mind and an open heart.**



**Rainbow District School Board invites  
everyone to visit their website for additional  
Distance Learning information:**

**<https://www.rainbowschools.ca/parents/coronavirus/>**

## A MESSAGE FROM DIRECTOR BLASEG



408 Wembley Drive, Sudbury, Ontario P3E 1P2 | Tel: 705.674.3171 | Toll Free: 1.888.421.2661 | [rainbowschools.ca](http://rainbowschools.ca)

May 4, 2020

### **DISTANCE LEARNING: ON MOTIVATION, MARKS AND MORE**

Dear Parents/Guardians:

As we enter week five of distance learning, we celebrate Education Week. It's an opportune time to thank students and parents/guardians for your ongoing commitment to learning together while safely apart.

Our shared goal is to ensure the successful completion of the school year for all students, and to support students to advance to the next school year, earn credits and to graduate.

We recognize the important role we all play in keeping students motivated and engaged. Teachers continue to have high expectations for students and we want students to continue to have high expectations for themselves. Distance learning is all about preparing for the future, so let's take a deep breath and stay the course. We know you can do it.

As always, please be assured that our educators and support staff will reach out to students and families who may require extra support and encouragement. If you have any questions or concerns, please connect with your child's teacher(s). We are here to help.

As we look ahead, we know you may have questions about final marks. Students will be graded on work completed prior to school closures on March 13th and, more importantly, can improve their marks from April 6th to the end of the school year with teacher-led distance learning. No student will be adversely affected due to school closures.

At the secondary level, exams are being replaced with culminating activities. Marks can only go up from what they were, so effort and performance count.

Grade 12 graduates will receive their Ontario Secondary School Diploma. In all likelihood, however, graduation ceremonies and proms will be postponed. Schools are considering options and will communicate directly with students and families.

During Education Week, I invite students to take time to reflect on how much you have achieved. Be proud of your accomplishments. We are certainly very proud of you.

Keep well and keep learning,

A handwritten signature in black ink, appearing to read "Norm Blaseg".

Norm Blaseg  
Director of Education

## A MESSAGE FROM PRINCIPAL RUNCIMAN



### Lockerby Composite School

1391 Ramsey View Court, Sudbury, Ontario P3E 5T4 | Tel: 705.522.1750 | Fax: 705.522.0658

Craig Runciman, HBA, MA, BEd, MEd  
Principal

Ryan Lafraniere, BSc (Hons), BEd, MEd  
Vice-Principal

May 4, 2020

Dear Viking Community:

AP Capstone

Home to the  
Science  
Technology  
Education  
Program  
(STEP)  
est. 1984

We hope that everyone in our community continues to do well during these unique times, as all families continue to face many challenges. As many of you are already aware, all schools in Ontario will remain closed until May 31<sup>st</sup>, 2020, and possibly longer, in order to contain the spread of COVID-19 and to keep everyone safe. Rainbow District School Board Director Norm Blaseg announced last week that the Ontario Ministry of Education has altered the school year calendar to allow for all remaining Professional Activity Days and examination days to become instructional time in order to maximize teacher-led distance learning.

Further to today's letter from Director Blaseg (posted on Rainbow District School Board's website), we continue to do our best to answer any challenges related to the implementation of the provincial and local distance learning framework. Lockerby Composite School continues to implement creative means, with all of its staff members, to make at-home learning a positive experience. As always, an overarching goal in supporting our Viking students has been to provide opportunities for them to demonstrate overall expectations in their Semester 2 classes and to achieve credits, while creating a supportive learning environment and building a sense of belonging for each of our students. At this time, please know that the following information is being shared across all Rainbow District School Board area schools:

- The Ministry of Education and Rainbow District School Board have indicated that the final marks for all students (elementary and secondary) will be based on work completed prior to school closures on March 13<sup>th</sup>, 2020. Marks can be improved with work completed and graded from April 6<sup>th</sup>, 2020 to the end of the school year with teacher-led distance learning. **It is critical that students have a solid foundation of the key learning expectations in order to prepare for the next year of learning. The goal is to continue with assessment and provide opportunities to develop necessary skills that will build foundational knowledge.**
- Since examination days have become instructional time, and in order to maximize teacher-led distance learning, there will be no final examinations in courses for this semester. All final examinations will be replaced with culminating activities. **It is critical that students remain engaged in their learning throughout the rest of the semester, as they will be required to complete these culminating activities in order to demonstrate an understanding of overall expectations.**

With that said, Rainbow District School Board's Distance Learning Plan continues to be a fluid document. Know that we will be sharing any and all new information and next steps (with respect to the above and otherwise) with the Viking community as soon as it becomes available. In the interim, attendance for classes will still be taken every day, and it is important for students to communicate proactively with their teacher(s) if they require additional support. Likewise, it is both the Ministry of Education and Rainbow District School Board's expectations that students continue to complete assigned work (with integrity and academic honesty) and do their best to meet timelines, commitments, and due dates.

Of course, our goal is always to continue to help support every learner as best we can and as always, the health and safety of students and staff is our first and foremost priority. Thank you for your patience as we continue this new journey together.

Sincerely,  
**LOCKERBY COMPOSITE SCHOOL**  
Per:

**CRAIG RUNCIMAN**  
Principal



## A MESSAGE FOR ALL ADVANCED PLACEMENT (AP) STUDENTS



### Lockerby Composite School

1391 Ramsey View Court, Sudbury, Ontario P3E 5T4 | Tel: 705.522.1750 | Fax: 705.522.0658

Craig Runciman, HBA, MA, BEd, MEd  
Principal

Ryan Lafraniere, BSc (Hons), BEd, MEd  
Vice-Principal

May 5, 2020



Dear AP Students and Parents/Guardians:

#### **RE: ADVANCED PLACEMENT (AP) EXAMINATIONS AND FINAL EVALUATIONS**

We hope that everyone is continuing to do as well as possible during these unprecedented times. We recognize that all families continue to face many challenges; and as we monitor the spread of the coronavirus (COVID-19), the health and safety of students and educators is of top priority. At this time, we would like to take the opportunity to provide you with key information updates regarding the 2020 AP College Board examinations and final evaluations. Below is a brief synopsis of some important details:

- Most examinations and final evaluations will have one or two free-response questions, and each question will be timed separately. Students will need to write and submit their responses within the allotted time for each question.
- For most subjects, the examination or final evaluation will be 45 minutes long, plus an additional 5 minutes for uploading. Students will need to access the online testing system 30 minutes early to get setup.
- The College Board 'AP Testing Guide' was released this past Wednesday, which provides information for students about the examination day process. This guide also provides information regarding their 'AP Exam e-ticket,' which identifies the steps for students to take before test day, the details of the test day experience, and the processing of scores, credit and placement.
- Lockerby Composite School teaching staff continue to communicate with students regarding this year's examinations and final evaluations as well as subject-specific changes and details. Staff continue to share the contents of the 'AP Testing Guide,' as well as the 'AP Examination Day Checklist.' Students are being asked to complete this checklist prior to each of their examinations and to keep it next to them while testing.
- Students will be able to take examinations and final evaluations on any device they have access to – computer, tablet, or smartphone. Students have also been asked by our staff to use the 'AP Exam Demo' to practice the different ways in which to submit their examination responses. This 'demo' will help students confirm that their testing device will be able to access and run the online examination.
- AP Research and AP Seminar courses will use portfolio submissions and will not have a separate online examination. Our staff will be communicating all portfolio submission changes and details to students.

At Lockerby Composite School, the following dates and times have been set aside for writing final examinations or final evaluations:

AP Calculus 'AB'	Tuesday, May 12 <sup>th</sup> , 2020 at 4:00pm
AP Computer Science 'A'	Friday, May 15 <sup>th</sup> , 2020 at 4:00pm
AP Biology	Monday, May 18 <sup>th</sup> , 2020 at 2:00pm
AP Research	Friday, May 22 <sup>nd</sup> , 2020 (portfolio uploading deadline)
AP Seminar	Friday, May 22 <sup>nd</sup> , 2020 (portfolio uploading deadline)

For those students challenging additional examinations or final evaluations, the following dates and times have been set aside:

Environmental Science	Monday, May 18 <sup>th</sup> , 2020 at 4:00pm
English Language and Composition	Wednesday, May 20 <sup>th</sup> , 2020 at 2:00pm
French Language and Culture	Thursday, May 21 <sup>st</sup> , at 12:00pm



## A MESSAGE FOR ALL ADVANCED PLACEMENT (AP) STUDENTS

- Page 2 of 2 -

As usual, students' work will be scored by a network of AP College Board faculty and AP teachers, and scores will be reported on a 1 – 5 scale. The AP College Board anticipates releasing scores as close to the usual July timeframe as possible. The AP College Board is confident that the vast majority of higher education institutions will award college credit as they have in the past. The AP College Board has spoken with hundreds of institutions across North America that support this year's examinations and final evaluations process.

Like many college and university-level examinations and final evaluations, this year's AP examinations and final evaluations will be open book/open note. The examination and final evaluation format and questions have been designed specifically for an at-home administration, so points will not be earned from content that can be found in textbooks or online. However, students taking the examinations and final evaluations may not consult with any other individuals during the testing period. The AP College Board will be taking the necessary steps to protect the integrity of each examination and final evaluation administration, as they do every year. Please note, that for the small number of students who may try to gain an unfair advantage, the AP College Board has a number of comprehensive and strict set of protocols in place to prevent and detect cheating.

In addition to Lockerby Composite School staff continuing to prepare students for successes on their AP examinations and final evaluations (in their AP Classrooms, Google Classrooms, and/or otherwise), the AP College Board (on Wednesday, March 25<sup>th</sup>, 2020) began offering free live AP review content, delivered by AP teachers from across North America. These lessons and their contents can be found on the AP College Board website.

Know that our Viking staff has been working diligently in continuing to prepare our students for success on their 2020 AP College Board examinations and final evaluations and at this time, we would like to take the opportunity to wish all of our AP students good luck . . . we know that you will do extremely well!

Should you have any further questions or concerns about these examinations and final evaluations, please do not hesitate to reach out to our subject-specific classrooms teachers.

Your Sincerely,  
**LOCKERBY COMPOSITE SCHOOL**  
Per:



**CRAIG RUNCIMAN**  
Principal

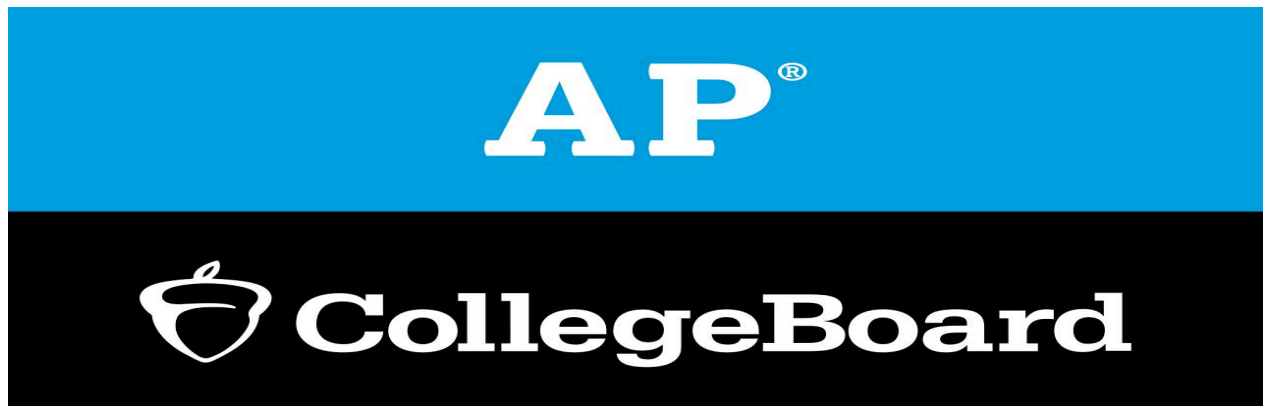

STUDENT COUNCIL TRIVIA WEEK!

**LOCKERBY COMPOSITE**

**T****r****i****v****i****a**

**@lockerbystudentscouncil  
will be hosting a trivia week  
from May 11th until the 15th**

**Join our Instagram page to  
play each day!**

## WHAT PARENTS NEED TO KNOW FOR OUR 'ONLINE' CLASSES NEXT WEEK . . .

Monday, May 11<sup>th</sup>

- LAA feature team released
- Student Council Trivia Week

Tuesday, May 12<sup>th</sup>

- AP Calculus Examination at 4:00pm

Wednesday, May 13<sup>th</sup>

- Grade 11 and 12 'Mark Summary' arrival by mail

Thursday, May 14<sup>th</sup>

Friday, May 15<sup>th</sup>

- AP Computer Science Examination at 4:00pm

**Our Newsletter is back each week from now until the end of the year. We continue to do our best to get information to our Viking Community. Our Newsletter will be our main means of communication for all of our families, as we continue distance learning. Thank you for your continued patience!**

### Let's Connect



<https://www.instagram.com/lockerbycomposite/>

<https://twitter.com/lockerbynet>

<https://www.facebook.com/lockerbyvikings/>

<https://lockerby.rainbowschools.ca/>

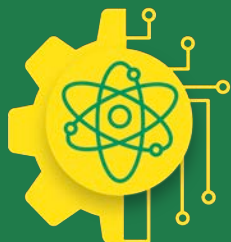

**Science and Technology Education Program**

**AP Capstone**